

FAULT DEVELOPED IN POWER TRANSFORMER: A REVIEW**Nisha Barle*, Rama Sarojinee, Manoj Kumar Jha**

Ph.D. Scholar, Department of Mathematics, Dr. C.V. Raman University, Bilaspur, India.

Department of chemistry, Govt. Dudhadhari Bajrangi girls college, Raipur, India.

Department of Mathematics, Rungta Engg. College, Raipur, India.

ABSTRACT

Power transformer is major power system equipment. Their reliability not only affects the electric energy availability of the supplied area, but also affects the economical operation of a utility. Determining transformer condition is useful for making short-term decisions regarding operation and maintenance. The major concern of the power transformer incipient faults is that they may decrease the electrical and mechanical integrity of the insulation system. Incipient faults of power transformers can be classified into the following major categories: electrical arcing, electrical corona, overheating of cellulose, overheating of oil. These faults may be caused due to one or more of the causes.

KEYWORDS: Power Transformer.

INTRODUCTION

Power transformers are ones of the most important components of electric networks. The majority of these devices have been in service for many years under different environmental, electrical and mechanical conditions.

The fault of a distribution transformer may leave thousands of homes without heat and light, and the fault of a step-up transformer in a power generation plant may cause the shutdown of the attached generation unit.

These devices are very expensive and therefore monitoring systems will be valuable for preventing damage to the transformers.

Generally speaking, monitoring is the observation of transformer conditions. The difference between offline monitoring and online monitoring is that the transformer should be switched off in order to measure data for the offline monitoring, and for the online monitoring the data can be acquired while the transformer is operating [1] - [4].

Starting from the new research outcomes that the incipient fault diagnosis in power transformers can assure information to foretell failures ahead of time, the needed corrective maintenance should be taken in account to stop outages and reduce down time.

EXTERNAL FAULTS IN POWER TRANSFORMER***a. External Short - Circuit of Power Transformer***

The short-circuit may occur in two or three phases of electrical power system. The level of fault electric current is always high enough. It depends upon the voltage which has been short-circuited and upon the impedance of the circuit up to the fault point. The copper loss of the fault feeding transformer is abruptly increased. This increasing copper loss causes internal heating in the transformer. Large fault electric current also produces severe mechanical stresses in the transformer. The maximum mechanical stresses occur during first cycle of symmetrical fault current.

b. High Voltage Disturbance in Power Transformer

High Voltage Disturbance in Power Transformer is of two kinds:-

- Transient Surge Voltage
- Power Frequency over Voltage

Transient Surge Voltage

High voltage and high frequency surge may arise in the power system due to any of the following causes,

- Arcing ground if neutral point is isolated.
- Switching operation of different electrical equipment.
- Atmospheric Lightening Impulse.

Whatever may be the causes of surge voltage, it is after all a traveling wave having high and steep wave form and also having high frequency. This wave travels in the electrical power system network, upon reaching in the power transformer, it causes breakdown the insulation between turns adjacent to line terminal, which may create short circuit between turns.

Power Frequency over Voltage

There may be always a chance of system over voltage due to sudden disconnection of large load. Although the amplitude of this voltage is higher than its normal level but frequency is same as it was in normal condition. Over voltage in the system causes an increase in stress on the insulation of transformer. As we know that, $V = 4.44\Phi.f.T \Rightarrow V \propto \Phi$, increased voltage causes proportionate increase in the working flux. This therefore causes, increased in iron loss and disproportionately large increase in magnetizing current. The increase flux is diverted from the transformer core to other steel structural parts of the transformer. Core bolts which normally carry little flux may be subjected to a large component of flux diverted from saturated region of the core alongside. Under such condition, the bolt may be rapidly heated up and destroys their own insulation as well as winding insulation.

c. Under Frequency Effect in Power Transformer

As, voltage $V = 4.44\Phi.f.T \Rightarrow V \propto \Phi.f$ as the number of turns in the winding is fixed. Therefore, $\Phi \propto V/f$
From, this equation it is clear that if frequency reduces in a system, the flux in the core increases, the effect are more or less similar to that of the over voltage.

Internal Faults in Power Transformer:-

The principle faults which occurs inside a power transformer are categorized as,

- Insulation breakdown between winding and earth
- Insulation breakdown in between different phases
- Insulation breakdown in between adjacent turns i.e. inter - turn fault
- Transformer core fault

INTERNAL EARTH FAULTS IN POWER TRANSFORMER

a. Internal Earth Faults in a Star Connected Winding with Neutral Point Earthed through Impedance

In this case the fault electric current is dependent on the value of earthing impedance and is also proportional to the distance of the fault point from neutral point as the voltage at the point depends upon, the number of winding turns come under across neutral and fault point. If the distance between fault point and neutral point is more, the number of turns come under this distance is also more, hence voltage across the neutral point and fault point is high which causes higher fault current. So, in few words it can be said that, the value of fault electric current depends on the value of earthing impedance as well as the distance between the faulty point and neutral point. The fault electric current also depends up on leakage reactance of the portion of the winding across the fault point and neutral. But compared to the earthing impedance, it is very low and it is obviously ignored as it comes in series with comparatively much higher earthing impedance.

b. Internal Earth Faults in a Star Connected Winding with Neutral Point Solidly Earthed

In this case, earthing impedance is ideally zero. The fault electric current is dependent up on leakage reactance of the portion of winding comes across faulty point and neutral point of transformer. The fault electric current is also dependent on the distance between neutral point and fault point in the transformer. As said in previous case the voltage across these two points depends upon the number of winding turn comes across faulty point and neutral point. So in star connected winding with neutral point solidly earthed, the fault electric current depends upon two main factors, first the leakage reactance of the winding comes across faulty point and neutral point and secondly the distance between faulty point and neutral point. But the leakage reactance of the winding varies in complex manner with position of the fault in the winding. It is seen that the reactance decreases very rapidly for fault point approaching the neutral and hence the fault electric current is highest for the fault near the neutral end. So at this point, the voltage

available for fault electric current is low and at the same time the reactance opposes the fault electric current is also low, hence the value of fault electric current is high enough. Again at fault point away from the neutral point, the voltage available for fault electric current is high but at the same time reactance offered by the winding portion between fault point and neutral point is high. It can be noticed that the fault electric current stays a very high level throughout the winding. In other word, the fault electric current maintain a very high magnitude irrelevant to the position of the fault on winding.

c. Internal Phase to Phase Faults in Power Transformer

Phase to phase fault in the transformer are rare. If such a fault does occur, it will give rise to substantial electric current to operate instantaneous over electric current relay on the primary side as well as the differential relay.

INTER TURNS FAULT IN POWER TRANSFORMER

Power Transformer connected with electrical extra high voltage transmission system, is very likely to be subjected to high magnitude, steep fronted and high frequency impulse voltage due to lightening surge on the transmission line. The voltage stresses between winding turns become so large, it cannot sustain the stress and causing insulation failure between inter - turns in some points. Also LV winding is stressed because of the transferred surge voltage. Very large number of Power Transformer failure arises from fault between turns. Inter turn fault may also be occurred due to mechanical forces between turns originated by external short circuit.

THE LEAKAGE FLUX IN THREE-PHASE TRANSFORMERS

In power transformers, not all the flux produced by the primary winding passes through the secondary winding, nor vice versa. Instead, some of the flux lines exit the iron via the air. The portion of magnetic flux that goes through one of the transformer windings but not the other is called leakage flux, and the amount of leakage flux mainly depends on the ratio between the reluctance of the magnetic circuit and the reluctance of the leakage path. Leakage flux lines in transformers are curved at the ends of the coils and flow through the air almost parallel to the winding axis. The degree of curvature of the lines is affected by the distance between the coils and the machine's shield and the latter's distribution in the air is influenced by the type of winding used in the machine's construction. Leakage flux lines in a healthy transformer have a horizontal axis of symmetry that passes through the middle of the magnetic core of the machine. When a short-circuit, or even a strong deformation, of one or several turns occurs, this symmetry is lost; therefore leakage flux can be used for the early diagnosis of insulation faults. Below, a simple theoretical approach for the analysis of the leakage flux in the windings of a power transformer is presented. This approximate analysis will show the symmetrical nature of leakage flux and will allow the establishment of the foundations for a diagnosis procedure. Theoretical results will be complemented with finite element models of transformers with different type of windings where the actual distribution of leakage flux will also be analyzed. The magnetic core and windings of a three-phase power transformer can be represented in an approximate way for the analysis of the leakage flux by means of the theory of the images.

Electromagnetic problems involving a planar perfect electric or perfect magnetic conductor can be handled through the image principle, in which the surface is replaced by image sources that are mirror images of the sources of magnetic or electric potential. This method can be easily applied to a core limb of a three-phase transformer in order to demonstrate the spatial symmetry of leakage flux. Fig.1 shows a graph with the application of this principle.

In the graph a core limb of a transformer with a single layer of winding is represented. For the sake of simplicity only the right side of the winding is used in the analysis. This simplification is reasonable since the contribution of the left-side winding to the leakage flux can be neglected if only the symmetrical or asymmetrical nature of the flux is being studied. Taking into account that the normal component of the magnetic

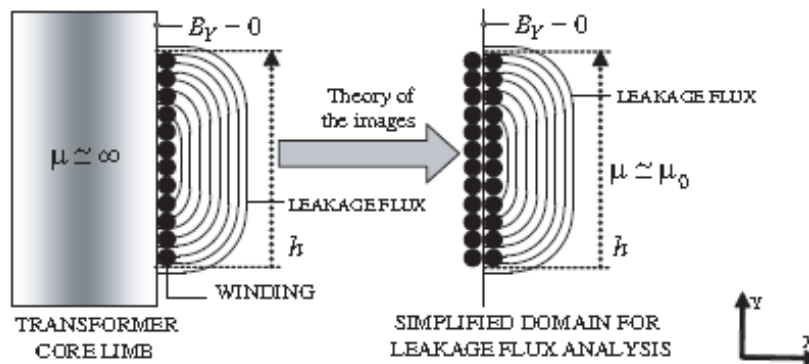

Fig.1 The leakage flux in three-phase transformers

Fig.1 Application of the image principle to a core limb of a three-phase transformer. Induction by is nil in the outside surface of the magnetic core, the theory of the images can be applied to the surface of the core limb. By simply adding a second layer of winding (image of the actual winding) at the internal face of the core, the same boundary conditions for the magnetic flux density are achieved. In this way, the leakage flux density in the outside of the core limb can be approximately calculated by obtaining the flux created by the two layers of conductors of the new simplified domain.

FAULTS - TYPES AND THEIR EFFECTS

It is not practical to design and build electrical equipment or networks so as to completely eliminate the possibility of failure in service. It is therefore an everyday fact of life that different types of faults occur on electrical systems, however infrequently, and at random locations. Faults can be broadly classified into two main areas which have been designated "Active" and "Passive".

Active Faults

The "Active" fault is when actual current flows from one phase conductor to another (phase-to-phase) or alternatively from one phase conductor to earth (phase-to-earth). This type of fault can also be further classified into two areas, namely the "solid" fault and the "incipient" fault.

The solid fault occurs as a result of an immediate complete breakdown of insulation as would happen if, say, a pick struck an underground cable, bridging conductors etc. or the cable was dug up by a bulldozer. In mining, a rock fall could crush a cable as would a shuttle car. In these circumstances the fault current would be very high, resulting in an electrical explosion.

This type of fault must be cleared as quickly as possible, otherwise there will be:-

- Greatly increased damage at the fault location. (Fault energy = $I^2 \times R_f \times t$ where t- is time)
- Danger to operating personnel (Flash products).
- Danger of igniting combustible gas such as methane in hazardous areas giving rise to a disaster of horrendous proportions
- Increased probability of earth faults spreading to other phases.

Higher mechanical and thermal stressing of all items of plant carrying the current fault, (Particularly transformers whose windings suffer progressive and cumulative deterioration because of the enormous electromechanical forces caused by multi-phase faults proportional to the current squared).

Sustained voltage dips resulting in motor (and generator) instability leading to extensive shut-down at the plant concerned and possibly other nearby plants.

The “incipient” fault, on the other hand, is a fault that starts from very small beginnings, from say some partial discharge (excessive electronic activity often referred to as Corona) in a void in the insulation, increasing and developing over an extended period, until such time as it burns away adjacent insulation, eventually running away and developing into a “solid” fault.

Other causes can typically be a high-resistance joint or contact, alternatively pollution of insulators causing tracking across their surface. Once tracking occurs, any surrounding air will ionize which then behaves like a solid conductor consequently creating a “solid” fault.

Passive Faults

Passive faults are not real faults in the true sense of the word but are rather conditions that are stressing the system beyond its design capacity, so that ultimately active faults will occur. Typical examples are:-

- Overloading - leading to overheating of insulation (deteriorating quality, reduced life and ultimate failure).
- Overvoltage - stressing the insulation beyond its limits.
- Under frequency - causing plant to behave incorrectly.
- Power swings - generators going out-of-step or synchronism with each other. It is therefore very necessary to also protect against these conditions.

Transient & Permanent Faults

Transient faults are faults which do not damage the insulation permanently and allow the circuit to be safely re-energized after a short period of time.

A typical example would be an insulator flashover following a lightning strike, which would be successfully cleared on opening of the circuit breaker, which could then be automatically reclosed. Transient faults occur mainly on outdoor equipment where air is the main insulating medium.

Permanent faults, as the name implies, are the result of permanent damage to the insulation. In this case, the equipment has to be repaired and reclosing must not be entertained.

POWER TRANSFORMER INCIPIENT FAULTS

Power transformers are ones of the most important components of electric networks. The majority of these devices have been in service for many years under different environmental, electrical and mechanical conditions.

The fault of a distribution transformer may leave thousands of homes without heat and light, and the fault of a step-up transformer in a power generation plant may cause the shutdown of the attached generation unit.

These devices are very expensive and therefore monitoring systems will be valuable for preventing damage to the transformers.

Generally speaking, monitoring is the observation of transformer conditions. The difference between offline monitoring and online monitoring is that the transformer should be switched off in order to measure data for the offline monitoring, and for the online monitoring the data can be acquired while the transformer is operating.

Starting from the new research outcomes that the incipient fault diagnosis in power transformers can assure information to foretell failures ahead of time, the needed corrective maintenance should be taken in account to stop outages and reduce down time. The purpose of this paper is to study different methodologies of incipient fault monitoring and to develop a new monitoring procedure for power transformer.

TYPES OF FAULTS

The faults that occur within the transformer protection zone are internal faults. Transformer internal faults can be divided into two classifications: internal short circuit faults and internal incipient faults. Internal short circuit faults are generally turn-to-turn short circuits or turn to earth short circuits in transformer windings. Internal incipient

transformer faults usually develop slowly, often in the form of a gradual deterioration of the insulation due to some causes.

Statistics show that winding failures most frequently cause transformer faults (ANSI/IEEE 1985). Insulation deterioration, often the result of moisture, overheating, vibration, voltage surges, mechanical stress created during transformer through faults, are the major reason for winding failure.

Voltage regulating load tap changers, when supplied, rank as the second most likely cause of a transformer fault. Tap changer failures can be caused by a malfunction of the mechanical switching mechanism, high resistance load contacts, insulation tracking, overheating, or contamination of the insulating oil.

Transformer bushings are the third most likely cause of failure. General aging, contamination, cracking, internal moisture and loss of oil can all cause a bushing to fail. Two other possible reasons are vandalism and animals that externally flash over the bushing. Transformer core problems have been attributed to core insulation failure, an open ground strap, or shorted laminators.

Other miscellaneous failures have been caused by current transformers, oil leakage due to inadequate tank welds, oil contamination from metal particles, overloads and over voltage. The factors responsible for failures and accelerated deterioration can be categorized as:-

- Operating environment (electrical): load current, short circuits, lightning and switching surges;
- Operating environment (physical): temperature, wind, rain, pollution;
- Operating time: time in service and time under abnormal conditions;
- Number of operations of tap changer;
- Vibration effect: sound and material fatigue;
- Contaminants: moisture, presence of oxygen and particles in oil.

A correlation between the causes and the effects produced at the flaw is presented in Table3.1. Usually, one fault type may have more than one cause.

Example: Arching and/or overheating of solid insulation may have as cause winding turn-to-turn short-circuit; arching and corona discharges may have as cause free water or excessive moisture in oil, etc. This makes fault location very difficult. Nevertheless, fault diagnosis is good enough to provide information to a maintenance program, and serve as the basis of a preventive maintenance strategy.

Table 1 Correlation between power transformer internal faults and causes.

Causes	Faults			
	Arcing	Corona	Overheating of Cellulose	Overheating of Oil
Winding turn-to-turn short-circuit	X		X	
Winding open circuit	X		X	
Operation of build in LTC	X			
Winding distortion or displacement		X	X	
Lead distortion or displacement		X	X	
Loose connection to bushing terminals, tap leads, terminal boards	X	X	X	

Free water or excessive moisture in oil	X	X		
Floating metal particles	X	X		
Loose connection to corona shields		X		
Loose collars, spacers, core ground straps, core hold down angle (Braces)		X		
Through fault			X	
Overloading			X	X
Damaged yoke bolt insulation				X
Rust or other damage on core				X
Damaged shunt packs of tank				X
Jammed oil circulating path				X
Cooling system malfunction				X

METHODOLOGY OF INCIPIENT FAULT MONITORING

Dissolved gas analysis has become a very popular technique for monitoring the overall health of a transformer. As various faults develop, it is known that different gases are generated. By taking samples of the mineral oil inside a transformer, one can determine what gases are present and their concentration levels. Researches have been done to connect theoretically the gaseous hydrocarbon formation mechanism with the thermodynamic equilibrium. Some studies indicated that the hydrocarbon gases with the fastest rate of evolution would be methane, ethane, ethylene and acetylene. Some studies have focused on key gases and what faults they can identify.

In Table 2 the relationship between fault types and the key gases is shown. In the case of key gas analysis, a fault condition is indicated when there is excessive generation of any of these gases. For this to be effective, much expert experience is still needed.

Table 2 The relationship between fault types and key gases.

Key gas	Chemical symbol	Fault type
Hydrogen	H ₂	Corona
Carbon monoxide and Carbon dioxide	CO CO ₂	Cellulose insulation Breakdown
Methane and Ethane	CH ₄ C ₂ H ₆	Low temperature Oil Breakdown
Acetylene	C ₂ H ₂	Arcing
Ethylene	C ₂ H ₄	High temperature oil breakdown

For example, acetylene concentrations that exceed the ethylene concentrations indicate that extensive arcing is occurring in the transformer, since arcing produces acetylene.

In addition to gas in the oil, it is an accepted fact that the presence of water is not healthy for power transformers. Water in the oil indicates paper aging, since the cellulose insulation used in power transformers is known to produce

water when it degrades. Water and oxygen in the mineral oil further increases the rate at which the insulation will degrade.

This means that a high concentration of water in the oil not only indicates that the insulation has been degrading but it will degrade more quickly in the future due to increased presence of water in the oil. Water in the oil is also a sign that the mineral oil itself is deteriorating. When the mineral oil deteriorates, the dielectric constant of the oil decreases. The key gas method identifies the key gas for each type of fault and uses the percent of this gas to diagnose the fault. It interprets dissolved gas analysis results based on a simple set of facts. In Table 3 is summarized the diagnostic criteria of the key gas method.

Table 3 Diagnostic criteria of key gas method

Fault	Key gas	Criteria
Arcing	Acetylene(C ₂ H ₂)	Large amount of H ₂ and C ₂ H ₂ and minor quantities of CH ₄ and C ₂ H ₄ , CO and CO ₂ may also exist if cellulose is involved
Corona(PD)	Hydrogen(H ₂)	Large amount of H ₂ , some CH ₄ , with small quantities of C ₂ H ₆ and C ₂ H ₄ , CO and CO ₂ may be comparable if cellulose is involved
Overheating of oil	Ethylene(C ₂ H ₄)	Large amount of C ₂ H ₄ , less amount of C ₂ H ₆ , some quantities of CH ₄ and H ₂ , Traces of CO
Overheating of cellulose	Carbon monoxide(CO)	Large amount of CO and CO ₂ Hydrocarbon gasses may exist

Though moisture and dissolved gas analysis are helpful in detecting many types of failures that can occur in a transformer, the measurement of partial discharges is the most effective method to detect pending failure in the electrical system. As the electrical insulation in a transformer begins to degrade and breakdown, there are localized discharges within the electrical insulation. Every discharge deteriorates the insulation material by the impact of high-energy electrons, thus causing chemical reactions. Partial discharges may occur only right before failure but may also be present for years before any type of failure. A high occurrence of partial discharges can indicate voids, cracking, contamination or abnormal electrical stress in the insulation.

The most common method for on-line detection of partial discharges is the use of acoustical sensors mounted external to the transformer. The main difficulty with using acoustical sensors in the field, however, is in distinguishing between internal transformer partial discharges and external partial discharges sources, such as discharges from surrounding power equipment. An alternative method has been proposed recently to differentiate between internal and external partial discharges and is based on the combined use of signals from a capacitive tap and signals from an inductive coil fitted around the base of the bushing.

The advantage of partial discharges sensors is the ability to detect the actual location of insulation deterioration, unlike the dissolved gas sensors. The one disadvantage to partial discharge sensors is that they are greatly affected by the electromagnetic interference in the substation environment. One of the simplest and most effective ways to monitor a transformer externally is through temperature sensors. Abnormal temperature readings almost always indicate some type of failure in a transformer.

It is known that as a transformer begins to heat up, the winding insulation begins to deteriorate and the dielectric constant of the mineral oil begins to degrade. In order to make on-line monitoring possible, thermocouples are placed externally on the transformer and provide real-time data on the temperature at various locations on the transformer. In many applications, temperature sensors have been placed externally on transformers in order to estimate the internal state of the transformer.

Though the breakdown of the insulation can cause catastrophic failure in a transformer, the life of a transformer is predominantly shortened by the deterioration of its accessories. These accessories include the bushings, load tap changers and cooling system.

Some of the causes of bushing failures include changing dielectric properties with age, oil leaks, design or manufacturing flaws, or the presence of moisture. Sensors have now been created to monitor the health of bushings. Transformer bushings have a finite life.

Overheated load tap changers can result from many different phenomena. These causes include coking, misalignment, and loss of spring pressure. Though the contact temperature cannot easily be measured directly, the overheating will generally result in an increase in the load tap changer oil temperature. By monitoring the load tap changer temperature closely, the flashover between the contacts can be avoided, which usually results in a short circuit of the regulating winding and subsequent failure of the transformer. Vibration analysis by itself cannot predict many faults associated with transformers, but it is another useful tool to help determine transformer condition. Vibration can result from loose transformer core segments, loose windings, shield problems, loose parts or bad bearings on oil cooling pumps or fans. Every transformer is different, therefore, to detect this, baseline vibration tests should be run and data recorded for comparison with future tests.

Vibration analyzers are used to detect and measure the vibration. Information gained from these tests supplements ultrasonic and sonic fault detection tests and dissolved gas analysis. Information from these tests may indicate maintenance is needed on pumps/fans mounted external to the tank. It may also show when an internal transformer inspection is necessary. If wedging has been displaced due to paper deterioration or through faults, vibration will increase markedly.

CASE STUDY: FAULTS AND DEFECTS IN POWER TRANSFORMERS

A power transformer is one of the most important and costly devices in electrical systems. Its importance is attributed directly to the continuity of power supply, since its loss through failure or defect means a supply stoppage. This is a large piece of equipment whose substitution is expensive and involves a lengthy process.

Research for new technologies and new predictive maintenance techniques has greatly contributed to reduce supply stoppages, thereby ensuring improved reliability of energy supply. Several studies highlight the importance of optimizing maintenance processes and diagnoses of substation equipment such as transformers. In this context, the purpose of this research was to study faults and defects that occurred in 34.5 kV, 69 kV, 138 kV and 230 kV power transformers immersed in mineral oil for a period of 28 years at the electric power concessionaire (CELG), which supplies over two million consumers distributed in 237 municipalities with a population of approximately four million in the state of Goiás, Brazil. A defect is considered an anomaly in a device that can cause it to operate irregularly and/or below its nominal capacity. If not corrected in time, this defect can evolve, leading to failure of the equipment and its removal from service.

A fault is an anomaly in a piece of equipment that inevitably causes stoppage of its operation, forcing its removal from service. As it is used here, the term “stoppage” indicates that the service of a piece of equipment was interrupted, i.e., it was removed from operation due to a defect or fault. The word “transformers” also refers to autotransformers.

Power Transformers

The present work was developed based on:-

- The identification of the main parts of power transformers, which were analyzed and divided into blocks of components, as shown in Fig.2 and
- The characterization and analysis of faults and defects ducted in these devices, resulting from stoppages and / or interventions which they underwent.

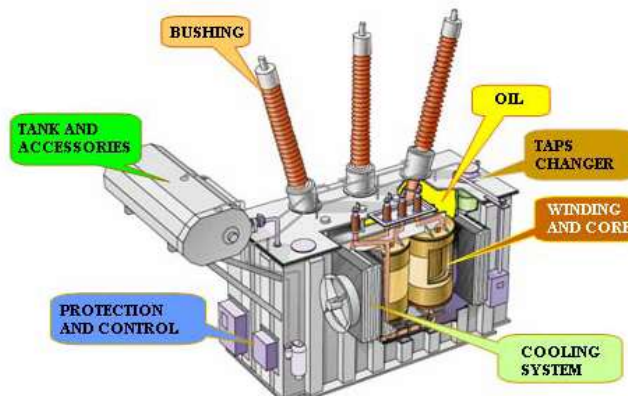

Fig.2 Power Transformers

***Stoppages in the electric power system due to transformer defects and Faults
Number of Stoppages of the Devices***

In this study, 549 service stoppages were recorded from December 1979 to May 2007, involving 255 three-phase transformers or three-phase transformer banks, and several of these devices showed more than one stoppage. Of the transformer service stoppages in the period considered in this work, a certain number were due to faults and other defects, as indicated in Table 4, reaching a total of 549 stoppages in this period of 28 years.

Table 4 Number of Transformer Stoppage

Stoppages caused by	Number of stoppages	Percent (%)
Faults	413	75.2
Defects	136	24.8
Total	549	100

It should be noted that this study took into account the devices that were removed definitively from operation as well as those that were purchased over the 28-year period of this study. It is estimated that 10% of the devices under study are part of the total number of transformers that belong to the system's technical reserve over these years.

Number of Transformer Stoppages versus Damaged Components

Fig. 3 shows the percentage of transformer stoppages versus damaged components in the period of 1979 to 2007, without considering stoppages caused by the protection system and by human error. In this study, it was found that the components most affected were windings (34%), bushings (14%), on load tap changers, OLTC, (10%), and de-energized tap changers, DTC (10%). The item "unidentified component" (11%) refers to components which lack reliable records for several reasons. The insulation system of the transformers in question is composed of mineral oil and solid insulation (cellulose, varnish or polyester), although most of it consists of oilpaper. It was found that the stoppages due solely to problems in the insulation oil accounted for only 4% of the number of stoppages during the 28 years analyzed here. The degradation of a transformer's insulation system is usually the main parameter that causes electrical faults in these devices.

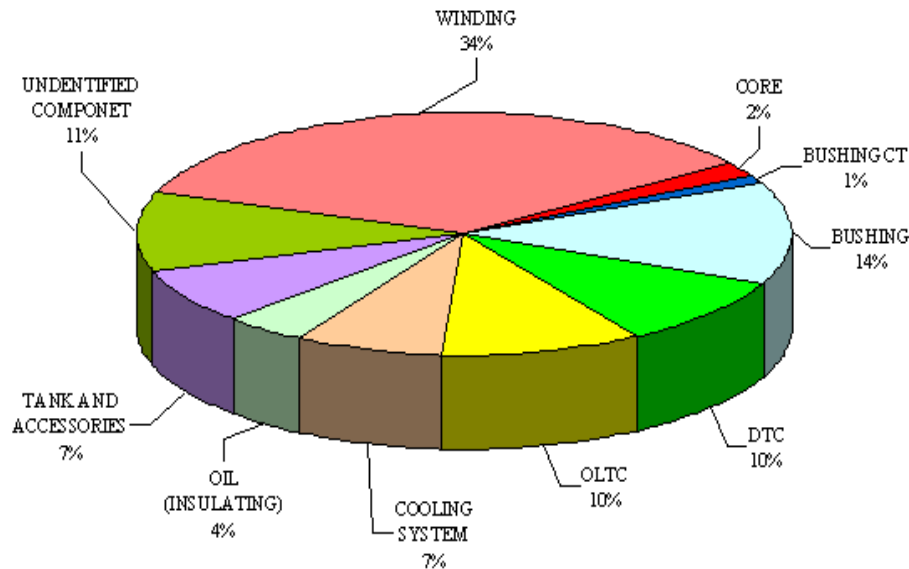

Fig. 3 Number of transformer stoppages versus components

The aging of oil-paper insulation in a transformer depends on aging of both the paper and the oil. The assessment of the remaining life of a transformer is the desired result of diagnostic procedures. A popular belief is that the life of the insulation paper determines the transformer's service life. Thus, when factors of transformer insulation degradation such as water, oxygen, the products of decomposition in the oil and temperature are monitored and controlled continuously, there is decrease in the degradation of the insulation system, which means less risk of electrical faults. (CELG) carries out systematic physicochemical testing and analyses of dissolved gases to control and monitor the insulating oil of its transformers, which is the reason for the low percentage of problems involving insulating oil in its devices (4%).

Throughout its operation, a power transformer has to withstand numerous stresses that generally result in the degradation of the oil-paper insulation system by decomposition of the paper and/or oxidation of the oil.

Degradation reduces the quality of this insulation. Partial discharges can lead to winding breakdowns, and may cause accelerated aging. PDs must be inferred in order to build an early warning system. In this context, PDs serve as an important measuring parameter for on-line monitoring.

AGGREGATE EFFECTS OF THROUGH FAULTS ON POWER TRANSFORMERS

A 1000MVA Three Phase Generator Step-UP (GSU) Transformer at a Generating Station suffered a catastrophic electrical fault in October 2005. This resulted in a significant impact to the Operating Companies revenue stream as this base-loaded facility, minus a functional (GSU) Transformer could not export Power for 17 days until a temporary (De-rated Output) Transformer was installed. Another full rated spare transformer was installed in early 2006 during the scheduled plant shutdown to replace the smaller unit. The new replacement Transformer (with an up-rated power rating) is scheduled for installation in early 2008.

Power transformers are designed and built by manufacturers to withstand the large mechanical and electrical stresses imparted on the transformer due to the maximum electrical fault energy postulated for that transformer. Secondary side transformer faults also expose the transformer to elevated mechanical and electrical stresses that are functions of:-

- The nature of the fault (3 phase fault, ground fault etc.,
- The magnitude of the fault (function of the equivalent system reactance where the fault occurs), and
- The time necessary for a protective device to clear the fault.

Consequently, the challenge is to identify all transformers through faults, capture the energy profile of each individual through fault, and ascertain the consequences of the aggregate effects to the transformer.

ANATOMY OF THE POWER TRANSFORMER FAILURE

A root cause evaluation was conducted and the most significant contributor to the fault was believed to be the aggregate effects of through fault events since the transformer had undergone internal inspection and repair in 1996. Due to the mechanical and electrical stresses and physical shock imparted on transformers upon exposure to each through fault, it is theorized that these aggregate effects caused by forces over time manifested in looseness of the low voltage bus bar supports enabling the bus bars of two of the low voltage phases to migrate towards each other to the degree that the dielectric properties of the oil alone could not preclude a phase to phase fault from propagating.

A broadness review was instituted as a component of the root-cause evaluation and it was discovered that there are recent documented instances where cumulative through faults have led to comparable transformer faults. As a corrective action for the event, the existing maintenance program has been improved by requiring consideration of the frequency, the magnitude, and the duration of through faults experienced when evaluating maintenance indicators that would lead to more detailed inspections and repair actions for transformers.

EXTENT OF THIS PROBLEM

As an extension of the aforementioned root cause evaluation, additional searches were conducted to ascertain failure correlations within the nuclear industry. There were several instances where it was suspected that a power transformer failure was attributed to aggregate through faults. One utility transformer maintenance group has observed a pattern of transformer failures following ice storms that is believed to be highly correlated to an accumulation of through fault events on the failing transformers. A review of (IEEE) papers revealed some potential correlations with this phenomenon, however for the sake of brevity, the following case study entitled ‘Analysis of a Generator Step-Up Transformer Failure Following a Faulty Synchronization’ is offered to emphasize the cumulative effects of through faults. Essentially the authors indicated that in this case there were 42 faults below the current rating on phase 2 for the Muskingum River # 5 (GSU) and 37 prior through faults above the 1.0 per unit value that individually should not cause a transformer failure; however the cumulative effect may have been sufficient to loosen the windings and mechanical blocking to the extent that the through fault capability had been reduced prior to the out of phase synchronization.

SYSTEM CONFIGURATION AND FAULT TYPES

A commonly used station one-line configuration is shown in Fig. 4, where the generator and the step-up transformer have essentially the same rating. We should recall that the location of a fault will determine the severity or level of fault current. With a fault postulated at C1, the fault current through the Step-up transformer is mostly due to the generator contribution with auxiliary system contribution (generally negligible). In the case of a fault assumed at B1, the fault current through the Step-up transformer is mostly due to the system contribution but also has additional short circuit contribution from the auxiliary system. Yet, the highest available fault current tends to be at the Auxiliary system transformer due to the contribution of both the System via the Step-Up Transformer and the direct connected generator. It is noted that the auxiliary system fault will subject the Auxiliary system transformer to a few cycles of short circuit forces, while limiting the longer term thermal input associated with generator coast down, even when the Generator breaker is included in the system configuration.

NUMBER OF TESTS

The real world has shown that the asymmetrical current does not always follow the pattern of being evenly distributed events where one out of every three (or two out of every six) occurs evenly or randomly across the phases. In the real world case it was observed through the historic records that the failed phase had been subjected to multiple faults that involved downed lines and a high voltage breaker failure. One may postulate that if the fault current with a high degree of asymmetry occurs repeatedly, or consecutively, on the same phase; then a close inspection and verification of fitness for service is warranted.

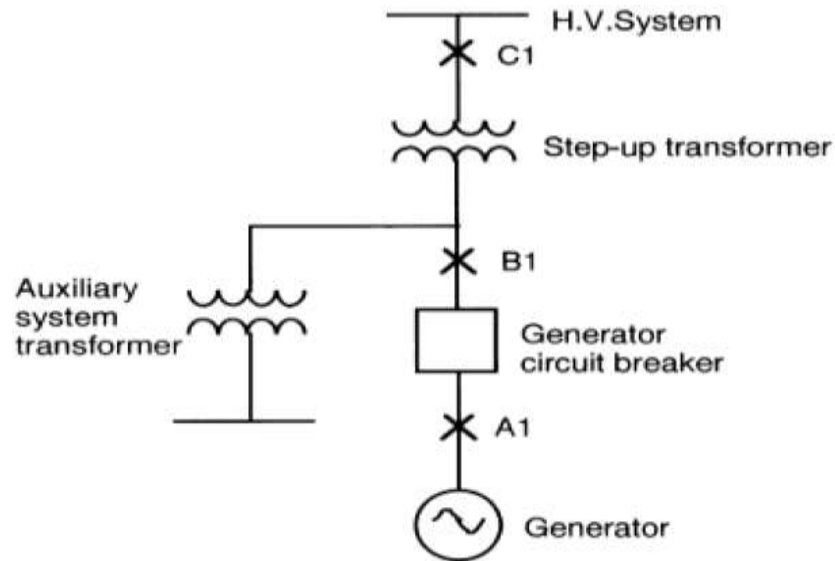

Fig.3.4 Single-line diagram of unit generator system

FAULT TRACKING PROGRAM ATTRIBUTES

The increased sensitivity to the effects of through fault currents on large transformers has motivated some individual plant sites as well as the organizations responsible for the utility distribution system to evaluate the effectiveness of their maintenance programs. A major contributor to an effective program for inclusion of through fault tracking and analysis is to identify and obtain the base-line data needed for future analysis. It is most desirable of course to obtain this data while the transformer is in a healthy state. Preferably this will be performed in the manufacturers shop prior to delivery. It can also be established after a transformer has undergone major refurbishment or maintenance.

Another major aspect of a through fault monitoring program is the identification of the through fault event and the capturing of the data necessary to support the analysis. There can be two parts to capturing this data. The primary source for a power plant is the protective relaying and on-site Fault Recorder data acquisition system. It should be verified that the Fault Recorder data acquisition system is set up to be triggered (start the data acquisition) at the proper level of fault current (recommendations may be as low as 0.25 per unit, or at a threshold level commensurate with the transformer design margin) and that adequate voltage and current readings will be taken for the three phases at the appropriate locations. A secondary source of valuable data can be secured from the transmission system group. Operational Experience (OE) has documented cases where events on the grid, which happened away from the plant site, contributed to transformer failure at the site. Formal communication with the appropriate contacts within the transmission system group could provide information about grid events where the magnitude of the event as seen at the site of the transformer is under the threshold for triggering the data acquisition system, but which would be useful in analyzing the accumulated effects of through fault events on a transformer.

Supplemental data necessary for the analysis of the transformer health is the result of periodic oil samples, Dissolved Gas Analysis (DGA), power factor testing, Frequency Response Analysis (FRA) testing, and infrared imaging thermograph readings. Proper trending of this data should support the analysis performed in response to a through fault event and over time help to validate recommendations for continued operation.

There are numerous inputs, which need to be considered when performing the post through fault event analysis of transformer health. Transformer age, electrical loading, any movement due to physical relocation, physical design, (OE), maintenance and inspection history, as well as the through fault event data and results of subsequent testing are a few considerations.

The physical design of the transformer will help to determine the failure modes that might be possible. Differences between transformer designs may necessitate the use of different strategies in the specifics of post event testing and analysis. While comparison of testing results taken after a through fault event to the base-line data can show potential movement or shifting of the coils, it may not show movement of bus bars or other internal components, which can eventually cause failure of the transformer. (OE) has shown that oil sampling and (DGA) will not always detect transformer degradation of this type either. (OE) has also shown that some transformer designs are physically more robust than others and alternatively others are more sensitive and as such are more likely to experience these failure modes. This will introduce an additional degree of subjectivity into the engineering analysis and weight the decision for instituting an internal inspection.

CONCLUSIONS

Power transformer is major power system equipment. Their reliability not only affects the electric energy availability of the supplied area, but also affects the economical operation of a utility. Determining transformer condition is useful for making short-term decisions regarding operation and maintenance. The major concern of the power transformer incipient faults is that they may decrease the electrical and mechanical integrity of the insulation system. Incipient faults of power transformers can be classified into the following major categories: electrical arcing, electrical corona, overheating of cellulose, overheating of oil. These faults may be caused due to one or more of the causes.

A monitoring procedure is conceived to take into consideration all the aspects regarding the incipient faults which appear in transformers. This will allow establishing a monitoring strategy regarding the diagnosis of the power transformer faults.

Every expert system that is created consists of numerous set of If-Then possibilities. The design of different expert systems will depend on the sensor measurements available and the type of failures being detected. The key to a successful expert system is to utilize all the knowledge known about the system.

Although the failures rates and the number of stoppages that occurred during the period under study were relatively low, it is important to implement other predictive techniques that are sensitive to incipient faults in power transformers-especially in terms of problems involving windings, bushings and tap changers, which, taken together, account for 68% of the events in components of these devices-in order to further improve the performance quality indicators reported here. Among these techniques, this paper highlights the measurement of partial discharges by the acoustic emission method, which could be allied to the (DGA) method, a technique well-known in the energy sector, thereby increasing the maintenance efficiency and quality of electric power supply.

REFERENCE

- [1] Shintemirov, W. Tang and Q. H. Wu. (2009), "Power Transformer Fault Classification Based on Dissolved Gas Analysis by Implementing Bootstrap and Genetic Programming", IEEE transactions on systems, man, and cybernetics—part c: applications and reviews, Vol. 39, No. 1, 69-79.
- [2] Adriana Rosa, Garcez Castro, Valdimiro Miranda (2005), "Knowledge Discovery in Neural Networks with Application to Transformer Failure Diagnosis," IEEE Transactions on Power Systems, Vol. 20, No. 2, 717-724.
- [3] Alff, J.J., Der Houhanessian, V., Zaengl, W.S., Kachler A. (2000), "A Novel Compact Instrument for Measurement and Evaluation of Polarization /Depolarization Currents Conceived for On Site Diagnosis of Electric Power Apparatus", IEEE Intern. Sympos. Electr. Insul. USA, 161-167.
- [4] Duval M, DePablo A. (2001), "Interpretation of Gas-In-Oil Analysis Using New IEC Publication 60599 and IEC TC 10 Databases", IEEE Electrical Insulation Magazine, 17(2): 31-41.
- [5] Duval, M., Dukarm, J. (2005), "Improving the Reability of Transformer Gas – in Oil Diagnosis.", IEEE Electrical Insulation Magazine, Vol. 21, No. 4, 21-27.
- [6] E. Dornenburg, W. Strittmatter (1974), "Monitoring oilcooled transformers by gas analysis", Brown Boveri Review, 5(61):238.47.
- [7] Farag A.S, Mohandes M., Al-Shaikh A (2001), "Diagnosing Failed Distribution Transformers Using Neural Networks", IEEE Transactions On Power Delivery 16(4):631-636.

- [8] Fredi Jakob, Paul Noble, and James J. Dukarm, (2012) “A Thermodynamic Approach to Evaluation of the Severity of Transformer Faults” ,Power Delivery, IEEE Transactions, Vol. 27, No. 2, 554 – 559.
- [9] Gubanski, S. M., Boss, P., Csepes, G., Der Houhanessian, V., Filippini, J., W. Guinic, P., Gafvert, P., Karius, V. Lapworth, J., Urbani, G. Wertelius, P. Zaengl (2003),”Dielectric Response Methods or Diagnostics of Power Transformers”, IEEE Electrical Insulation Magazine, Vol. 19, No. 3, 12-17.